

REVISION HISTORY			
REV.	DESCRIPTION	DATE	DRAWN BY
1	ORIGINAL PRINT	6/12/2025	A. GUPTA

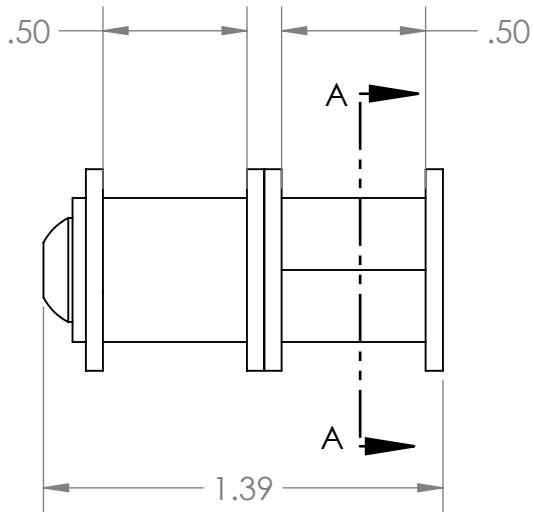

15T 0.5 MOD 30° P.A.
ISO 4156 SPLINE THRU
TIMING NOT REQUIRED

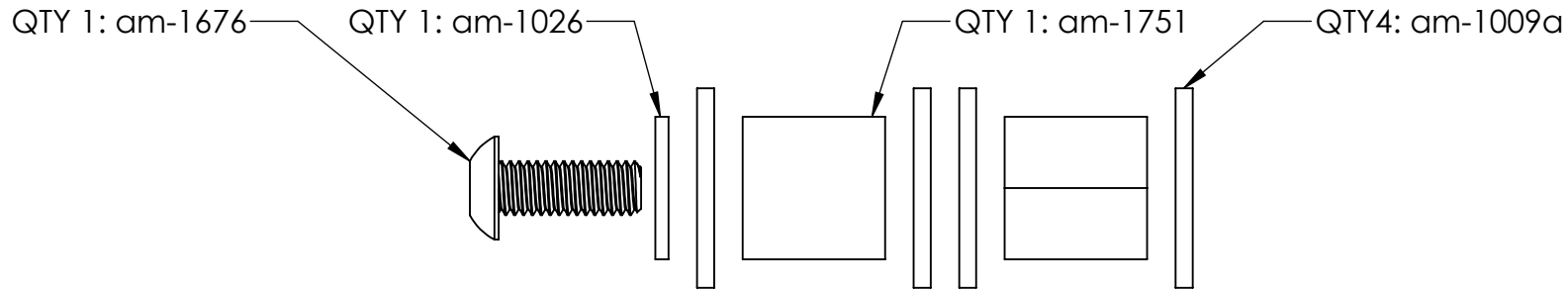
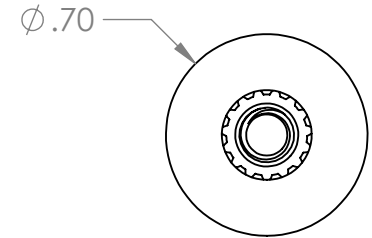
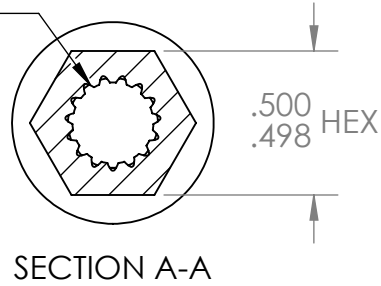

*** SEE CAD FOR ADDITIONAL TOOLPATH INFO***

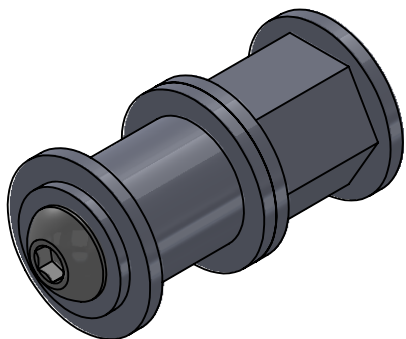

UNLESS OTHERWISE SPECIFIED:		COMMENTS:			
DIMENSIONS ARE IN INCHES		DUAL DIMENSIONS ARE IN MILLIMETERS.			
TOLERANCES:		BREAK ALL SHARP EDGES		TITLE: KRAKEN SPLINE TO 500 HEX ADAPTER 0.5IN LONG	
FRACTIONAL	±1/16			SIZE	DWG. NO.
ANGULAR: MACH	±1°			A	am-5663_short
ANGULAR: BEND	±5°				REV
ONE PLACE DECIMAL	±0.1				1
TWO PLACE DECIMAL	±0.01				
THREE PLACE DECIMAL	±0.005				
FOUR PLACE DECIMAL	±0.0005				
MATERIAL	STEEL	CHECKED	NAME	DATE	
FINISH	DEBURRED	ENG APPR.	NM	6/20/25	
		MFG APPR.			
		Q.A.			
DO NOT SCALE DRAWING				SCALE: 3:2	WEIGHT:
				SHEET 1 OF 1	